

INTERNATIONAL FEDERATION OF MODEL AUTO RACING



# IFMAR 1/8th 4WD I.C. Powered GT and electric GTE TRACK RACING TECHNICAL and RACE RULES 2024

First Version February 25<sup>th</sup>, 2017.

Amended March 12<sup>th</sup>, 2017.

Amended February, 2018.

Amended April 2018.

Amended August 4<sup>th</sup>, 2018, due to GBS measurement correction

Amended July 2019, due to several rule explanations

Amended November 2019, typos and Referees.

Amended December 2020, typos and Race officials to General part

Amended August 2021, due to postal vote changes

Amended March 2023, due to postal/vote changes.

Amended August 2023, minor formatting, clarification of existing technical rules.

Amended December 2023, after AGM

## Index:

1.	TECHNICAL RULES.....	3
2.	ENGINE RULES .....	5
3.	BODY RULES.....	6
3.1.	NUMBERING OF CARS .....	8
3.2.	NUMBERING OF THE BODY/WING .....	8
3.3.	HOLES IN THE BODY: .....	9
3.4.	BASIC SET OF ELECTRICAL RULES.....	9
4.	RACE FORMAT: .....	10
4.1.	TIRE SPECIFICATIONS:.....	15
4.2.	FUEL:.....	16
4.3.	PROHIBITED / NOT ALLOWED: .....	17
5.	GENERAL RULES for organizing IC powered 1/8 <sup>th</sup> GT Class:.....	18
5.1.	EVENT SCHEDULE: .....	18
5.2.	TROPHEES:.....	20
5.3.	TEAM MANAGERS / MEETING:.....	20
5.4.	TECHNICAL INSPECTION: .....	20
5.5.	OPENING CEREMONY: .....	21
5.6.	RACE PACKAGE: .....	21
5.7.	ACCESS TO PITS AND TRACK.....	21
5.8.	PITS: .....	21
5.9.	DISPLAY / DISTRIBUTION OF RESULTS:.....	21
5.10.	ROSTRUM:.....	21
5.11.	PADDOCK AREA: .....	22
5.12.	MARSHALLING: .....	22
5.13.	FLAGS:.....	23
6.	RACE-OFFICIALS / REFEREES:.....	23
6.3	PROTEST AGAINST A COMPETITOR OR ORGANIZER: .....	23
6.4	PENALTIES and SANCTIONS: .....	23
6.5	IN GENERAL: .....	24
	<b>IFMAR ASSOCIATED PLATINUM MEMBERS. ....</b>	<b>24</b>

1/8<sup>th</sup> GT IFMAR World Championships for track will consist out of 2 classes, IC powered and electric powered. Some different rules will apply for both classes due to race format and number of available controlled tires.

This set of rules for this class will consist of 5 parts:

- Technical rules, describing the cars measurements, weight and technical features
- Motor rules, specifying motor volume and internal specs.
- Body rules, including GBS specifications
- Race format, specifying race rules, controlled fuel and tires
- General rules, dealing with organizing, detailed schedules, explanations
- Officials / Referees

## 1. TECHNICAL RULES

The basic principle for this class is the use of off-road cars and/or off-road parts, although we cannot prohibit the use of a single designed car for GT in the future.

The chassis must have a minimum kick-off of 5 degrees in front. No carbon fibre chassis allowed. **The use of a kick-up will be again discussed after the 2025 WC event.**

The kick-off needs to have a minimum length of 30mm and lower suspension arms must be mounted on the kick-off. Kick off must start at a reference point from the middle point of the gearbox (or main gear), min 100mm / max 230mm.

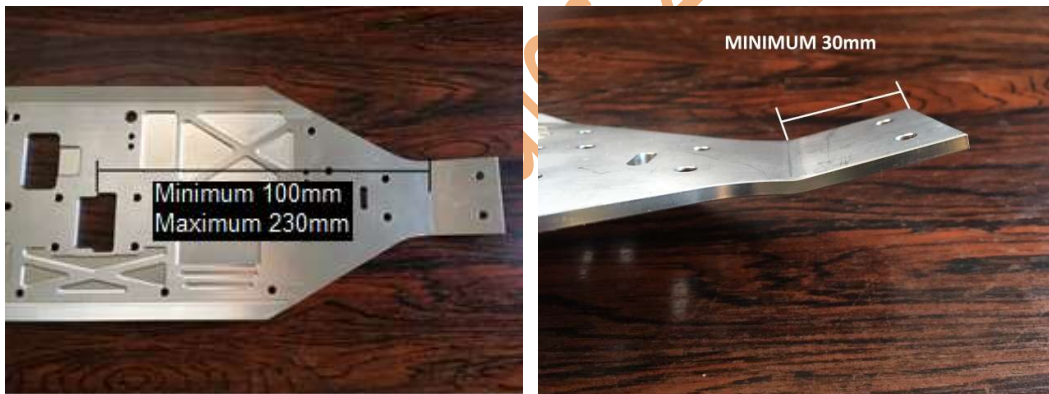

Drive shafts must be used all around. All driveshafts (4+2) must be made of steel **with magnetic properties** (no lightweight materials like Aluminium or Titanium).

Brake System: Maximum 2 brake system in Central Drive Shaft / Central braking only on crown wheel (spur gear). Only standard mechanical brakes are permitted. Up to two brake discs are permitted anywhere on the centre driveshaft's. Brakes may not be located on the outboard axles.

One-ways, spools, locking "Torsion-type," or externally adjustable differentials are not permitted. Front & Rear geared Differentials can only be tuned with the use of silicone-based oils. No center differential allowed. Ball differentials not allowed/only gear differentials. Front and Rear differential gear ratios must be identical. Front or rear underdrive or overdrive is not permitted.

The rear differential must be “finger proof”, so it must be at least partly covered in case of an open differential.  
The final drive ratio front and rear must be the same.

Overall dimensions of the chassis:

Height: minimum height 155,0mm with chassis plate on 20mm blocks.  
Wheel base between 320-379mm  
Length Maximum: 590mm  
Width max 310,0mm, including wheels, axles and wheel-nuts.  
The maximum capacity for the fuel tank is 150cc max, including all internal tubing.

The front of the car must be equipped with a bumper made from flexible “foam” material with all corners and edges rounded off. The contour of the bumper will follow the contour of the body. The bumper may not protrude in front of the body.

Minimum dimensions 200 x 20mm (height). There should be minimum 20mm foam material available to absorb any impact, **both on top as on the bottom.**

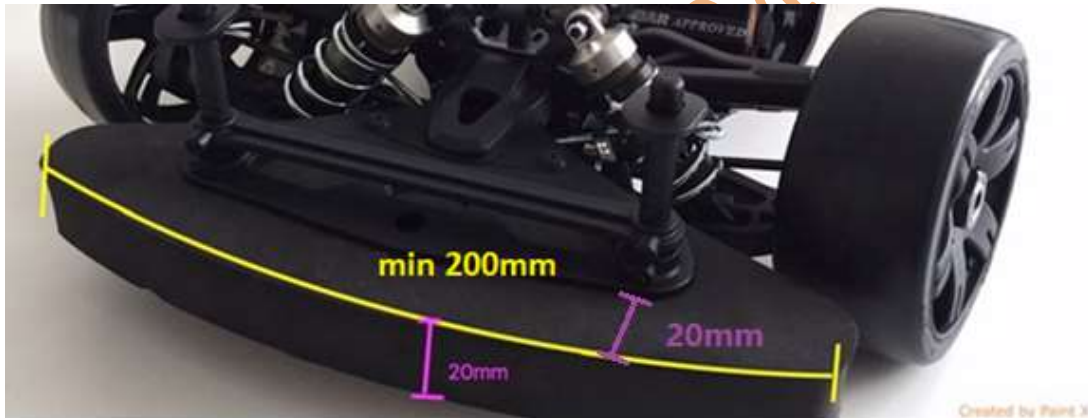

The Clutch must be a centrifugal type with a maximum of 4 shoes. No axial engagement of the shoes (No “Centax” Type clutches). Clutch must use radial centrifugal shoes only in conjunction with Std parallel sided cylindrical clutch bell similar design to the unit shown. A design where the spring adjustment part makes an axial movement and the clutch shoes only move radial should be allowed.



Direct Drive, i.e., single speed or maximum two speed gear box

Minimum weight in order to run with empty tank is 3500 grams.

## 2. ENGINE RULES

Engines allowed will be .21 or 3.5cc engines.

Maximum carburettor diameter is 7mm. The engine shall be air cooled. Conical plugs allowed  
Number of Ports. For IFMAR World Championships the rule is; 3 Outlet ports, consisting of 1 (one) main Outlet port and 2 outlet booster ports, regardless the name and dimensions, every hole is to be considered as one of the 3 allowed.

A maximum of 5 inlet ports or booster ports. Any hole will be considered as one of the 5 allowed.

The definition of 'port' is a hole in the cylinder liner for fuel inlet or exhaust extraction. The inlet and exhaust holes/ports can be any regular recognised shape eg. Circle, Ellipse, Square, Rectangle, Triangle, Pentagon etc., or Polygon.

Shapes that are recognised as not being regular, shapes joined with a 'slot' or hole are not allowed. Corners and ends of any shape can be radiused and any individual side does not have to be a straight line. A maximum of two additional "lubrication" holes are allowed under the exhaust ports with the restriction they will start opening with the piston closing the exhaust port

Examples of allowed shapes: - A to J are allowed. Shapes W to Z are not allowed.

See Drawing:

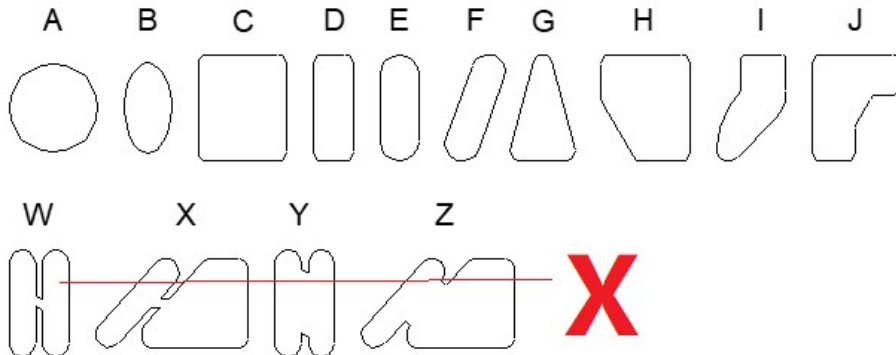

The use of an INS box is mandatory.

Due to some tuning restrictions on the engines this IC class runs heats of 6 minutes on one tank of 150cc fuel. So no refueling allowed during a heat.

All cars must be equipped with an approved / registered or homologated 3 chamber muffler according to the IFMAR muffler and INS box list.

A pipe extension on the muffler tailpipe is allowed with the provision that it does not amplify the exhaust sound beyond that normally produced by an approved muffler without extension. It is not allowed use some kind of trumpet to direct the exhaust fumes from the muffler outlet

pipe to the outside of the body that increases the DB level as measured at a distance of 1.0 metre above ground level.

### 3. BODY RULES

Bodies must be commercially available 1/8th scale GT1, GT2, Super GT, DTM, or V8 Supercar cars, 2 door GT bodies fitted with a separate wing like touring cars. The height of the wing at no point must not exceed 10mm higher than the highest point of the rooftop.

Note: The roof cannot be designed in such a way that ribs or fins are used to manipulate the height. The measurement of the height of the car is done on the highest point of the rooftop. Excluding any air intake scoops, ridges or any other extension from the actual true rooftop.

The wing is allowed to extend rearwards (overhang) a max of 20 mm at the furthest point measured from the rear bumper. Wing can be unpainted/clear. Wing width max 310 mm, including side plates, but never wider than the rear of the body. Maximum width body 317mm. Wing chord max 80 mm and Wing endplates maximum 40 x 80mm.

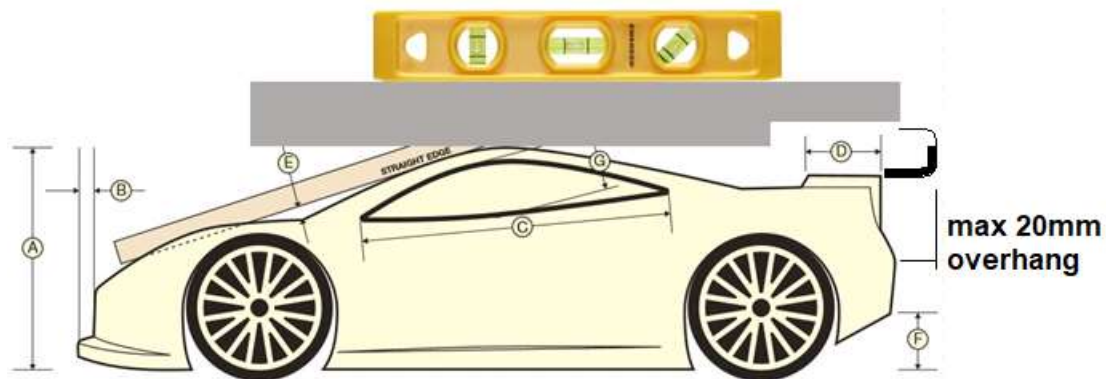

The "body must be mounted to the sprung mass of the car at front and rear". Mounting on the suspension uprights is not allowed.

The body must have visible windows, body panel and trim markings, and the windows must be mostly clear. Some intrusion for creative painting purposes and tinting is permitted, but the windows must be transparent. Bodies must have headlights and grill details. To avoid the use of lightweight bodies there is a minimum weight for a body. That minimum body weight is 260.0 grams, ready to race, painted, **with spoiler** and with stickers. The use of heat resistant tape or similar inside the body is allowed. Glue or similar adhesives are allowed to strengthen the body. It is not permissible to add weight to the body by any means such as the use of metal plates or similar. **For those using an extra piece of polycarbonate (flexible material only) glued or using plastic hardware inside the body as exhaust deflector the minimum weight is 265.0 grams.**

A 1 piece body moulding to avoid internal aerodynamics and or a diffuser mounted on the rear of the chassis is allowed. It must be not wider as the inner measurement of the wheels and may stick out of the body at the rear with a maximum of 20mm (same as wing

overhang). The diffuser must be made of flexible material without any sharp edges. No internal body supports / stiffeners / braces allowed to avoid lightweight bodies with internal modifications and add-ons, excluding reinforcement of the wheel arches and back boot lit is allowed. The body must rest on a maximum of 7 posts, of which 5 can protrude outside the bodies. Bodies must be made from **Polycarbonate**. The wing must rest on maximum 3 body posts which are not wider as 50x 20 mm each.

The body must be made from an existing car design, for which the name must be mentioned on the request for homologation. After been approved the name of the body is free to avoid license fees etc. Bodies must be within the GBS dimensions by IFMAR. See drawings enclosed.

Only bodies that are recognized and approved by IFMAR will be allowed. Bodies may be homologated by ROAR, EFRA, FEMCA or FAMAR and must have an ID number. Bodies need to be available commercially 3 months before the event. The combined list from the blocs will be valid for the WC event.

Concours d 'Elegance. This class is ideally suited for such a Concourse, with many original painting schemes available. All bodies used for official racing must be painted/stickered properly. Preferably a minimum of 2 painted/sprayed colours. Bodies used in the Concours must be used in the official racing. Only in case the body is damaged the driver can change after agreement with the race director.

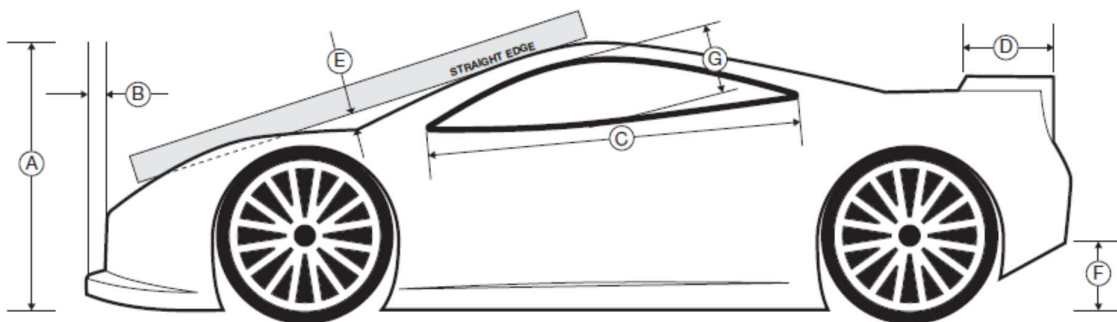

- A) Minimum 155,0mm (with chassis on 20mm blocs),
- B) Maximum 15 mm depth
- C) Minimum 170mm
- D) Maximum 3 posts 50mm x 20 mm
- E) Minimum 12,0mm, gap between straight edge bottom and hood plane where it meets windshield.
- F) Maximum 75,0mm (with chassis on 20mm blocs)
- G) Minimum 36mm



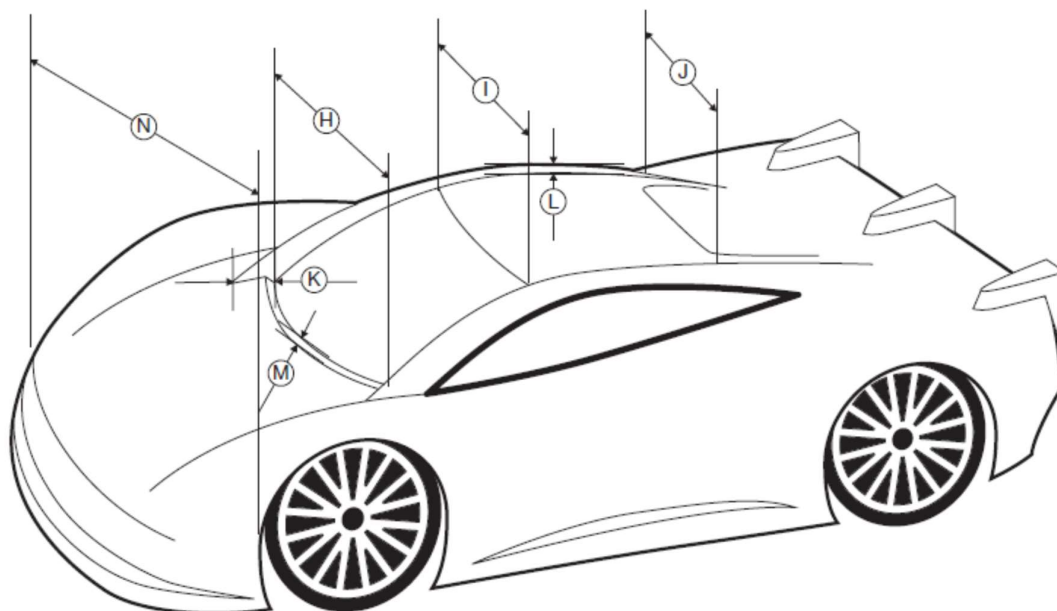

- H) Minimum 200mm
- I) Minimum 145mm
- J) Minimum 130mm (top inside edge of C-pillar)
- K) Maximum 8mm depth of A-pillar above the windshield surface plane
- L) Maximum 5mm height of outer roof rail above the roof surface plane
- M) Maximum 4mm stagger between hood and windshield
- N) Maximum 317mm, minimum 300mm overall width

### 3.1. NUMBERING OF CARS

Cars will be numbered 1 to 10 or 1-12 in each heat. The car must have 3 numbers. Only the numbers supplied by the organizer will be used on the cars. They may not be cut out to eliminate the background. 2 Numbers on the sides in front of the rear wheels, 1 in front on the hood or window

These numbers will change during the qualifying heats (after re-seeding).

The organiser will provide other numbers for altered heats and for sub-finals and final.

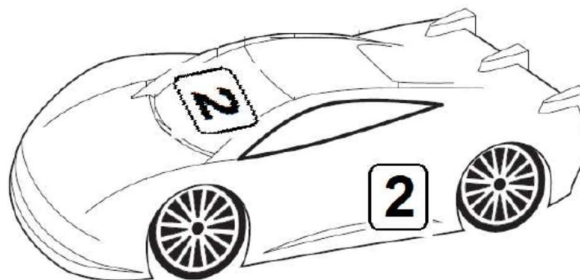

### 3.2. NUMBERING OF THE BODY/WING

The registration number (1-150/180, with number 1 being the reigning world champion) is put on the body/wing. It is the same for the entire competition.

The numbers provided by the organiser must be attached to the right side of the body/wing, the other side being reserved for the competitor's national flag. Every competitor may have his national flag on the left side of the body/wing of his car (when looking from the rear).



### 3.3. HOLES IN THE BODY:

Holes in the body for fuel-gun, fuel tank opener, aerial, glow-plug, carburettor access and exhaust. Rear and side windows may be removed. Maximum height of 75mm cut-out at rear on 20mm blocks. One opening may be made in the front windscreen with a maximum dimension of 80.0mm in any direction for refuelling and/of engine cooling. An additional hole for refuelling in the roof of 50mm is allowed and 35mm for the glow plug. Minimum distance between holes is 5mm. See drawings

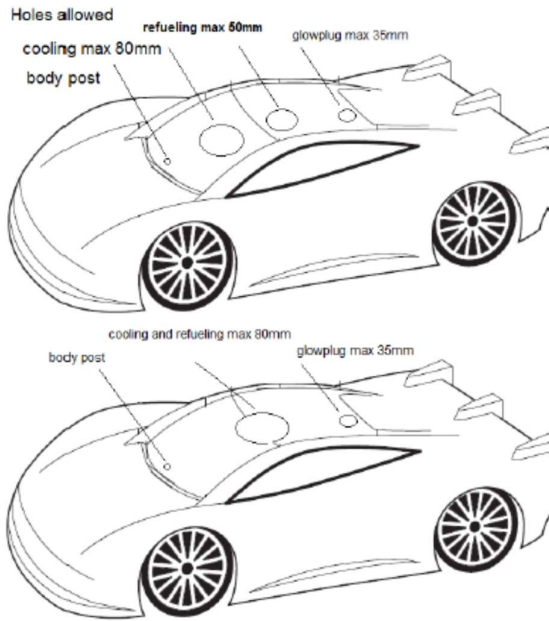

### 3.4 BASIC SET OF ELECTRICAL RULES

The following basic rules will apply.

Brushless motors with the following maximum dimensions:

Diameter: max. 44 mm

Length: max. 75 mm

Motors with and without sensor are allowed. For 2025 Motors need to be homologated and a list with homologated motors must be available 3 months prior to an event

4S LIPO battery: Any kind of battery will be allowed as long as it is commercially available. Maximum 4S (4 elements in series) will be allowed in a single pack or in two packs of equal characteristics of 7.40 V/7.60 V. The brand, voltage, Manufacturer, etc. must be visible on each battery, not valid those batteries that have lost the original manufacturer's labels/instructions. Mandatory HARDCASE. The maximum voltage is 16.80 Volt at the start of the race. The batteries and Chargers must have an equalizer cable. The Chargers must have a program Specific for LIPO/LIFE load, i.e., CC/CV (constant current, voltage cut), with Cut according to the specifications of the IFMAR regulation and the load must be made with the cable Equalizer. The maximum permissible current for charging is up to manufacturers specification. It is mandatory to use a safety bag for the batteries during charging.

For 2025 batteries need to be homologated and a list with homologated batteries must be available 3 months prior to an event.

The controller (ESC) is optional. It is not allowed to set the reverse Gear. The maximum temperature of the battery should not exceed 55 degrees Celsius after the run.

In GT EP cars is not allowed to cut the front windshield. The antenna hole (10 mm) and side windows can be cut out. Rear window can be removed. Additional cooling holes in the front where normally is the radiator of the respective body are allowed. If the dimensions of a single hole is bigger than 10 x 12 mm the area needs to be covered from inside with a corresponding grid.

The electrical / electronic equipment consists of the battery (LiPo hardcase), controller (ESC) and a servo for steering. Electronic driving aids such as ESP and ABS are prohibited. Telemetry is allowed as long as their function is part of the remote control and the receiver, as well as the associated sensors. This applies also to passive devices for recording data, and video that have no device for radio transmission.

GT carbon chassis for electric allowed. GT carbon chassis for electric allowed and no kick-up necessary.

Minimum weight: 3800 grams

Length of the heat depending on track layout and after consultation with IFMAR between 5-7 minutes (Heats and finals).

*For Electric GTe class; penalties for battery voltage*

1S	2S	4S	
4.20 or <	8.40 or <	16.80 or <	ok
4.21-4.22	8.41-8.44	16.81-16.88	discharge
4.23-4.25	8.45-8.50	16.89-17.00	no access
> 4.25	> 8.50	> 17.00	DQ

“Discharge” means, only one time allowed to have your battery checked

“No access” means no driving in that specific heat/final

“DQ means” disqualification from the event

#### 4. RACE FORMAT:

7 Days total. Start Sunday, finished Saturday. Saturday afternoon till Monday evening registration. Friday/Saturday before the start of the event the track is closed to allow the organizer to prepare for the event. If needed this closure can be longer but must be announced in the stage reports.

**Sunday**, IPD, 1-day, free practice, no refuelling allowed in the pit lane. Maximum number of drivers on the rostrum is limited to 12, unless the track and rostrum are suitable for more drivers (after consultation with IFMAR).

**Definition: International Practice Day (IPD).**

Drivers who have not driven on the track for 12 Months prior, this may include out of town drivers from the host country who have not driven on the track The host track has the ability to run events as they wish open to all drivers up to 6 days before registration day. Any drivers who have run on the track either during an event or attending a private practice session cannot use the international practice sessions.

The host track must keep a register of all drivers who use the track for preceding year, they need only register once.

The punishment for drivers found to be contravening the rule or the spirit of the rule will be determined by IFMAR and the host bloc of the person in question.

This is due to the possibility we may find out long after the event that there has been a contravening of the rule and may need to be addressed retrospectively.

IPD will be open practice, unless the number of drivers is too high and controlling is needed. IFMAR has the right to implement controls or restrict track time if it deems controls are necessary for the benefit of all drivers.

This is due to the possibility we may find out long after the event that there has been a contravening of the rule and may need to be addressed retrospectively.

**Monday**, General practice for all for 1 day. Depending on the number of drivers 4 till 5 rounds with maximum 12 drivers on the rostrum.

Tuesday, Timed practice for all 1 day + opening ceremony. Depending on the number of drivers 4 rounds with 3 best consecutive laps as result. Each round you will get points. With 4 rounds 2 rounds to count for seeding. Fastest 10 drivers will be placed in the last heat, etc. Point system in use for seeding the heats after timed practice. 2 results out of 4 rounds

Wednesday/Thursday, 2 Days of Qualifying, heats of 6 minutes duration **after a warm-up of 3 minutes and with rolling start**, no refuelling, or 12 minutes with one time refuelling. **For the rolling start a count-down will be given by the computer 3 minutes, 2 minutes, 1 minute, 30 seconds, 10 seconds, 5/4/3/2/1.** This 6 minutes as minimum should also help avoiding excessive engines tuning. During all finals no refuelling before the first 6 minutes mark. **A time penalty will be given in case a car is refuelled before the 6 minutes mark. The length of the time penalty to be announced before qualifying starts.**

Example: For 120 drivers (IC+E), 12 heats. Start R1 0800-1100, R2 1100-1400, R3 1430-1730.

Second day R4 0800-1100, R5 1100-1400, R6 1430-1730, Superpole

**For IC**; TQ in points of the Qualifying rounds goes straight into the main final. Number 2 till 5 will run Super pole for an extra place into the main final. Super Pole consists of the drivers of Position 2 till 5 in the final ranking after the last Qualifying Round. Each driver will drive the 'super-pole' individually on the track.

Procedure for Superpole:

5 minutes warm up for all participants together. Everybody back to the pitlane / staging area Then, one by one 3 minutes warm up for each driver with flying start system, followed by 6 consecutive laps.

(Remark: when warm up time is over and driver cross the starting line, he can only enter in the pits for adjustment of the engine). If any mistake stops or brake the car, this driver lost the rest of time or laps.

The 'superpole' running order will be 5, 4, 3, 2. The driver that scores the fastest lap will also move up straight to the 'Main' Final and take the second position on the starting grid.

All Super Pole drivers to use controlled tires, from your bag/box. This is a condition of entry to Super-Pole

Track conditions must be the same for all drivers, if necessary, track must be swept clean.

The 'super-pole' running order will be 5, 4, 3, 2.

The other drivers from the 'super-pole' will start in the semi-finals as per qualifying ranking.

TQ and Super pole winner will get track time after the quarter finals, 20 minutes total.

*After the practice from the TQ and winner from the Superpole both cars will go into Parc Ferme at technical inspection.*

Qualifying schedule order for round 1 till 6					
Wednesday			Thursday		
Round 1	Round 2	Round 3	Round 4	Round 5	Round 6
Heat 1	Heat 1	Heat 1	Heat 1	Heat 1	Heat 1
Heat 2	Heat 2	Heat 2	Heat 2	Heat 2	Heat 2
Heat 3	Heat 3	Heat 3	Heat 3	Heat 3	Heat 3
Heat 4	Heat 4	Heat 4	Heat 4	Heat 4	Heat 4
Heat 5	Heat 5	Heat 5	Heat 5	Heat 5	Heat 5
Heat 6	Heat 6	Heat 6	Heat 6	Heat 6	Heat 6
Heat 7	Heat 7	Heat 7	Heat 7	Heat 7	Heat 7
Heat 8	Heat 8	Heat 8	Heat 8	Heat 8	Heat 8
Heat 9	Heat 9	Heat 9	Heat 9	Heat 9	Heat 9
Heat 10	Heat 10	Heat 10	Heat 10	Heat 10	Heat 10
Heat 11	Heat 11	Heat 11	Heat 11	Heat 11	Heat 11
Heat 12	Heat 12	Heat 12	Heat 12	Heat 12	Heat 12

Friday/Saturday, Christmas tree finals, 20 minutes for subfinals, 30 minutes for semi-finals and 60 minutes for main final. **Electric finals, A/B/C etc.**  
Depending on track layout 10 or 12 drivers in the final.

There will be six (6) qualifying rounds. The length of the Heat is 6 minutes (without refueling) or 12 minutes (one Refueling allowed) and will depend on number of drivers and time available between sunrise and sun-set. For each round drivers will get points, based on number of laps and time of finishing lap.

Six (6) rounds of qualifying heats will be run as follows:

Wednesday approx. 08.00- 18.00, depending on sun-rise: Rounds 1, 2 and 3

Thursday, Rounds 4,5 and 6

Schedule every day is heat 1-15, 1-15, 1-15. IFMAR reserve the right to change the order.

The heat order must be made clear at drivers briefing.

In each round, drivers will score points based on the laps and times achieved. The number of points awarded to the best driver will be equal to 0, second position 2, points, 3rd position 3 points etc. *Up to last position one by one.*

In every round, in case of a tie, the points will be equally awarded to each driver, and the first driver not to tie, will receive one point less per tie.

For example:

1st driver will score 0 points

2nd driver will score 2 points

3rd driver will score 3 points

4th driver will score 4 points

5th driver 7 laps, 10:01:00 will score 5 points TIE

6th driver 7 laps, 10:01:00 will score 5 points TIE

7th driver 7 laps, 10:01:00 will score 5 points TIE

8th driver 7 laps, 10:10:00 will score 8 points

In the event of a tied position for the final Qualifying positions when 'best' scores are added together, only the scores (and laps/times) from counting Rounds added will be used to

decide the tie. The discarded Round scores (and laps/times) will not be used to decide any tie.

The driver with the lowest individual points within the Round scores added will be awarded the tie: (eg. 1+2+3=6 beats 2+2+2=6).

If the tie continues, the next best individual points will be considered: (eg. 1+1+4=6 beats 1+2+3=6).

If a comparison of points fails to break the tie, then the laps & times from each drivers lowest point scoring Round will be compared. The driver with the fastest laps & time from their lowest point scoring **Round will be** awarded the tie. In the unlikely event of these times being equal, then the second-best points scoring Round times will be used.

If a driver does not score a time (or has his time disqualified) in any Round, the driver scores points equal to 500.

Overall Qualifying Positions:

Out of six (6) Qualifying Rounds: each drivers best three (3) point scores (lowest) will be added to count for the Overall Ranking.

Out of five (5) Qualifying Rounds: each drivers best three (3) point scores (lowest) will be added to count for the Overall Ranking.

Out of four or three (4/3) Qualifying Rounds: each drivers best two (2) point scores (lowest) will be added to count for the Overall Ranking.

Out of two or one (2/1) Qualifying Rounds: each drivers best one (1) point score (lowest) will be used to count for the Overall Ranking.

All drivers will be entitled to a sub-final.

Friday/Saturday, Christmas tree finals, 2 Days for the finals  
Depending on track layout 10 or 12 drivers in the final

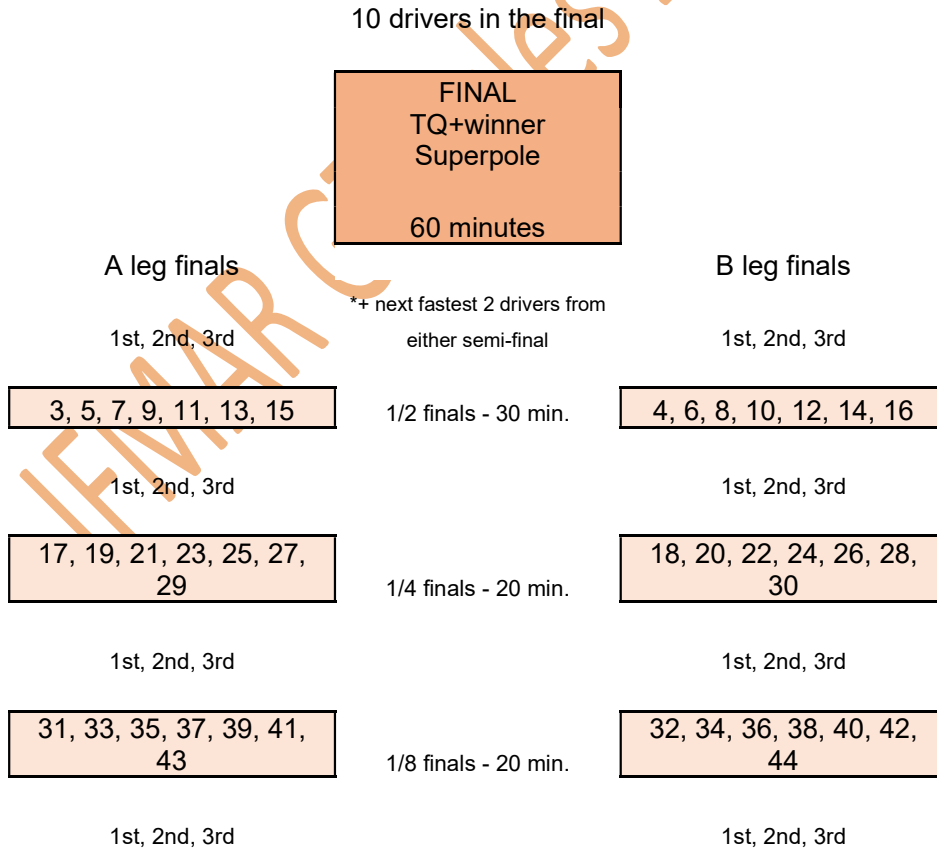

45, 47, 49, 51, 53, 55, 57	1/16 finals - 20 min	46, 48, 50, 52, 54, 56, 58
1st, 2nd, 3rd		1st, 2nd, 3rd
59, 61, 63, 65, 67, 69, 71	1/32 finals - 20 min.	60, 62, 64, 66, 68, 70, 72
1st, 2nd, 3rd		1st, 2nd, 3rd
73, 75, 77, 79, 81, 83, 85	1/64 finals - 20 min.	74, 76, 78, 80, 82, 84, 86
1st, 2nd, 3rd		1st, 2nd, 3rd
87, 89, 91, 93, 95, 97, 99	1/128 finals - 20 min.	88, 90, 92, 94, 96, 98, 100
1st, 2nd, 3rd		1st, 2nd, 3rd
101, 103, 105, 107, 109, 111, 113	1/256 finals - 20 min.	102, 104, 106, 108, 110, 112, 114
1st, 2nd, 3rd		1st, 2nd, 3rd
115, 117, 119, 121, 123, 125, 127	1/512 finals - 20 min.	116, 118, 120, 122, 124, 126, 128
1st, 2nd, 3rd		1st, 2nd, 3rd
129, 131, 133, 135, 137, 139, 141, 143, 145, 147, 149	1/1024 finals - 20 min.	130, 132, 134, 136, 138, 140, 142, 144, 146, 148, 150

12 drivers in the final

FINAL  
TQ+winner  
Superpole  
60 minutes

A leg finals

B leg finals

1st, 2nd, 3rd, 4th          \*+ next fastest 2 drivers from  
either semi-final          1st, 2nd, 3rd, 4th

3, 5, 7, 9, 11, 13, 15

1/2 finals - 30 min.

4, 6, 8, 10, 12, 14, 16

The car numbers for the eight (8) drivers who move up from the semi-finals to the main final are based on the results achieved out of both semi-finals, taking into account the laps and times only.

### Race Format for Electric GT class:

Practice and seeding same as IC GT

Qualifying, 6 rounds, point system. Tie breaker same as IC.

Qualifying; 1 out of 2 rounds / 2 out of 3 rounds / 2 out of 4 rounds / 3 out of 5 and 3 out of 6

First 10 after qualifying in the A-final, 11-20 in B-final etc.

Finals, 3 x A/B/C finals with point system best 2 out of 3.

The winner of final A1 and A2 (= already champion) cannot compete in A3.

#### 4.1. TIRE SPECIFICATIONS:

Controlled tires for all IFMAR events for IC GT and GTe class.

1 brand (IFMAR and the organizer shall open a bidding pool for manufacturers). The commercial part of the controlled tire is an agreement between organizer and manufacturer. IFMAR only to be informed because of the profit on a set. Once chosen for an event the same manufacturer is not allowed to supply tires for the next IFMAR GT event.

Tires for front and rear must have the same dimensions and

compound. The hardness of the compound must at least be comparable with PMT Q5 or harder. The tires must be made of rubber, no foam tires. An insert is allowed.

Tires must be limited per driver for practice and race with only 2 extra sets for the main IC final. For electric 1 set extra for the finals.

Tires must therefore be impounded, 1 box or bag per driver.

Holes in the rubber tires are allowed, so as the rim. Will be better for temperature.

No additives on the tires allowed under any circumstances.

Tires width, max 45mm

Rim measurement, spoke design, see picture. No dish like rims.

Rim Off set positive, 7 mm, with a tolerance of +/- 1mm because of the use of controlled tires.

The rims must have a minimum 75mm and maximum 85mm diameter.

The minimum diameter of a tire must have at any point in the race will be 98mm and maximum is 102mm. One compound to be used for the entire event under dry conditions and one specific different set in case of rain.

Wheels must use a 17mm hex hub consistent with the dimensions and function of the hubs used in 1/8 off road racing. The wheel must be affixed by a 17mm wheel nut, threaded on to the hex hub. Quick change mechanisms are not permitted.

Number of tires for an IFMAR event must be specified and will depend on track layout and tire wear.

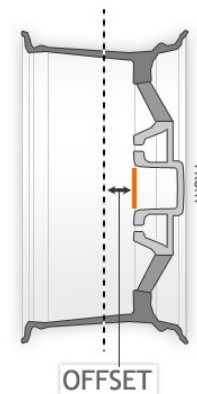



F.i. 1 sets for Practice, 2 sets for Qualifying+super-pole, 1 set extra for subfinals, 2 sets extra for main final. Or 3 sets for timed practice/qualifying/superpole and all subfinals with only **two** extra sets for main final. All used tires available for substitution. Tires will be marked with the driver's registration number.



#### 4.2. FUEL:

The Event is organized with controlled fuel. Fuel or fuels must *be commercially available*. Fuel may only contain methanol (methyl alcohol) CAS number 67-56-1, and/or Ethanol (Ethyl Alcohol) CAS number 64-17-5, lubricating oil, a small content of anti-corrosion chemicals and maximum 16% of nitro methane (Cas number 75-52-5) in volume. The specific gravity of the mixture may not be heavier than 0.87 grams/cc at 20°C and standard atmospheric pressure. Measurement will be done with a nitromax 16% in the pit lane and/or anywhere inside the venue. Any fuel detected heavier than 0.87 or containing more nitro as specified will mean that the driver will have the result deleted from the heat or final where the fuel was found to be illegal.

The following additives are strictly prohibited; Hydrazine, Hydrogen Peroxide, Toluene, Propylene Oxide, *but not restricted to other harmful/dangerous products*. *IFMAR has the right to take samples for analysing and penalties can be given to manufacturers that have used other ingredients or more nitro as mentioned in the rules.*

. Fuel suppliers are invited to make a submission to the event host for supply. Each supplier must send a (safety)datasheet with the complete ingredients to IFMAR 2 months before the event. More than one brand of fuel manufacturer up to a maximum of 3 brands will be allowed to sponsor an IFMAR 1/8<sup>th</sup> I.C. GT On-road World Championship event. If more than one brand of fuel is used, competitors must state their preferences on a selection form at least 6 weeks before the event. Switching to another brand during the event is only possible when there is enough fuel available. *Switching is only possible during Qualifying*. Every fuel manufacturer that is willing to sponsor an event must be able to supply fuel for the number of drivers that choose that brand + 15%. (The 15% extra is for drivers changing brand during the event).

**No fuel brand/manufacturer can ask or claim for exclusivity. The organizer should try everything possible to supply at least 2 different brands.** Safety storage for the different Official fuel suppliers must be secured. The different brands of official fuel must be available within the controlled area in cans of no more than 5 litres per brand. Fuel bottles must be supplied by the fuel manufacturers. There are no restrictions for a manufacturer in case of a next event.

Fuel supply either by organizer or the suppliers. The best offer will prevail. Deadlines will be 6 months (recommendations) and 3 months (decision)

In case no manufacturer is willing to sponsor an event than two brands of fuel will be chosen by the IFMAR I.C. Executive together with the race organiser.

*As for any fuel in general: A full safety data information sheet must be supplied on request with a break down of components, (Not necessarily brand names, i.e. type of oil castor, not the brand.)*

*IFMAR has the right to check and test fuels for compliance by any method deemed appropriate and may require samples prior to event for analysis*

*Suppliers are responsible for the shipping and delivery to the event in accordance with the local laws pertaining to the shipping and handling of such goods.*

*The event organizer is responsible for all aspects of the safe storage, handling and distribution of the fuel at the event.*

Race organizer recommends three (3) types of fuel in order of preference). The race organizer has to forward the recommendations to the IFMAR I.C. Section Chairman six (6) months before the event. The final decision will be made three (3) months before the event by a majority vote of the IFMAR I.C. Executive and all Blocs will be notified of the decision.

#### **4.3. PROHIBITED / NOT ALLOWED:**

Use of one-way bearings, except for the 1<sup>st</sup> gear of a 2-speed transmission.  
Belts.

Extra Body support struts for lightweight bodies, except those mentioned in the rules.

The use of traction control devices, active suspension devices and any steering control aided by gyroscopes/"G"-force sensors is strictly forbidden.

4-wheel brakes. Independent controlled braking on the front wheels is not allowed.

Hydraulic braking systems.

More than 2-speed transmissions.

Quick change wheel systems are not allowed, or the use of electric, spring or flywheel-based tools to change wheels.

Body extenders or wheel flares.

Tire-warmers.

#### **It is not allowed to use any electronic devices with the exception of:**

Two radio channels of the receiver which will be used to operate steering, throttle and brakes.

No more than two (2) servos.

A transponder for official counting.

An electronic failsafe.

Voltage regulator and/or battery level indicator.

#### **RADIO COMMUNICATION IS ALLOWED BETWEEN DRIVER AND MECHANIC.**

a: Only designated public service bands with a maximum power output of 500 mW are allowed.

b: Radio communication can only be used by the driver their pit crew, only while their driver is on the drivers' rostrum for the duration of the race.

c: A single ear piece or one-sided head set type that is not audible to others and does not reduce the ability to hear the referees' calls must be used.

d: All equipment must comply with the local & country radio communications rules.

e: Not allowed, any 2.4 GHz radio equipment.

f: Radio equipment cannot be used at any other time within or around the complex.

g: Race management has the right to test, decline or withdraw the use of any and all equipment without question.

Note: Rules, b, c & f, do not apply to race management.

**5. GENERAL RULES for organizing IC powered 1/8<sup>th</sup> GT Class:**

IC powered 1/8<sup>th</sup> Class GT will be run during odd years, in the same year as 1/8<sup>th</sup> IC track. The World Championship will be run over a period of seven (7) days excluding a spare day. Depending on the number of drivers we have the following number of allocations

Places will be initially allocated as follows:			
Entries	100	150	180
EFRA	20	30	35
FAMAR	20	30	35
FEMCA	20	30	35
ROAR	20	30	35
Host bloc	10	10	10
IFMAR	10	20	30

After distribution of the IFMAR places, the remaining places are to be distributed by the relevant IFMAR Section Chairman on a fair and equitable basis according to any extra requirements of the Blocs.

Depending on sun-set and sun-rise racing days will be 10-12 hours long, with a lunchbreak halfway if weather permits.

**5.1. EVENT SCHEDULE:**

Schedule and number of heat/rounds for practice can be changed, depending on number of drivers after or with consultation from IFMAR. The track surface should be prepared so that good quality practice will be obtained when practice commences. This may be achieved by a spraying and/or cleaning of the track surface, as required.

- Track open
- Friday till Thursday Track open
- Friday/ Saturday The track will be closed for 2 days to prepare. Or longer if the organizer needs more time. This needs to be announced in the stage reports.
- Saturday Track closed, registration 09.00-18.00 hours
- Sunday (IPD) Registration from 08.00 till 18.00
- Track open from 08.00-18.00 heats of max 15 registered drivers.
- Monday, controlled practice, all drivers 10 heats/15 drivers x 6, seeding end of the day based on 3 consecutive laps
- Tuesday, timed practice, up to 15 heats/10 drivers x 4, seeding based on 3 best consecutive laps. Heat length may vary depending on number of drivers between 5 and 10 minutes. For each round you get points (0 for 1<sup>st</sup> place, etc.) 2 out of 4 to count for seeding for Qualifying. IFMAR has the right to make adjustments to the seeding if they feel that this is needed due to unforeseen. Opening Ceremony.
- Wednesday 3 rounds of qualifying, qualifying is between 6/12 minutes
- Thursday 3 rounds of qualifying, qualifying is between 6/12 minutes
- Friday Lower finals, 20 minutes
- Saturday 1/8 ¼ ½ final, prize giving top 3 + banquet/prize giving top 24

Sunday giving

Spare day due to special circumstances on Saturday + prize

The car numbers for the drivers who move up from the semi-finals to the main final are based on the results achieved out of both semi-finals, taking into account the laps and times only. Parc ferme for semi-finalists after their final and TQ/Superpole drivers after their practice

**Example: Provisional Timetable Friday, based on 120 drivers total for electric and IC;**  
Some of the electric finals to be implemented in the schedule for Friday/Saturday.

Lower finals from 1/1024 to 1/8 to be run over 20 minutes.

Start time	B leg Finals		Start time	A leg Finals
09:00	1/256 B		09:30	1/256 A
10:00	1/128 B		10:30	1/128 A
11:00	Electric		A1/B1*	Electric
12:00	1/64 B		12:30	1/64 A
<b>13:00 – 14:00 LUNCHBREAK</b>				
14:00	Electric		A2/B2*	Electric
15:00	1/32 B		15:30	1/32 A
16:00	1/16 B		16:30	1/16 A
17:00	Electric		A3/B3*	Electric

\*Electric finals means A1/B1/C1 etc followed by A2/B2/C2, followed by A3/B3/C3 etc

Saturday: 1/8 & 1/4 finals to be run over 20 minutes.

Start time	B leg Final		Start time	A leg Final
09:00	1/8 B		09:30	1/8 A
10:00	1/4 B		10:30	1/4 A

11:00 – 11:30 Practice for the TQ+super pole winner, 20 minutes max.

11:30 – 12:00 Mandatory press conference or media presentation

**TQ/Super pole/Winner(s) electric class**

12:00 - 13:00 Lunchbreak

1/2 finals to be run over maximum 30 minutes.

Start time	B leg Final		Start time	A leg Final
13:00	1/2 B		13:45	1/2 A

**CHAMPIONSHIP FINAL TO BE RUN OVER ONE (1) HOUR**

- 15.30 Drivers presentation to the public
- 15.45 Warm-up Practice
- 15.58 Trial start
- 16.00 Start
- 17.00 End of the race
- 17.10 Unofficial publication of result
- 17.30 End of protest time
- 17.40 Prize ceremony on the track

#### **5.2. TROPHEES:**

Trophies must be available for all drivers in the main final, marked 1<sup>st</sup> till 10 (12) and for all drivers in the semi's, marked 11 or 13 till 22. **For the electric class Trophies must be available for all A main finalists and the top3 from the B/C/D etc finals.** A picture showing the trophies' must be send to the IC chairman approx. 3 months before the event.

#### **5.3. TEAM MANAGERS / MEETING:**

See General rules.

#### **5.4. TECHNICAL INSPECTION:**

Inspection will be on Saturday, Sunday and Monday from 08.00 until 18.30. A Schedule will be used for checking cars. Drivers or mechanics have to present their cars with bodies and empty tanks.

Only vehicles which conform to all regulations will be accepted for racing.

The cars will be examined and, if the car conforms to the rules, the chassis will be marked.

At any time, the Race Director may ask the competitors to present their cars to the Technical Inspector.

Random inspection will occur on the start line for numbers, tires, wings and chassis.

No race will be delayed because of non-compliance by a competitor. At the completion of each heat all cars in that heat, whether they finished or not, must be presented for technical inspection. Cars which are not presented for technical inspection at the end of a heat will be disqualified from that heat. Any race damage will be taken into account. At the end of finals, all cars will be impounded and may be inspected for engine size, fuel tank capacity, etc. The use of a non-homologated, modified homologated muffler will constitute disqualification from the event. The disqualified driver will be placed on the last position of the final qualifying results and/or the last position of the final positions' results and he will be noted as a disqualification.

Any technical infringement, other than those concerning engine, fuel tank, weight and muffler will cause disqualification from that heat or final and the disqualified driver's position will be shown as the last position in that heat or final.

All cars must be fitted with a clutch, a braking system and a homologated exhaust pipe.

The engine and fuel tank may be checked at any time.

The volume of the fuel tank will include all fuel piping and filters up to the carburetor. Only one car per driver will be accepted

Rain situation. Rounds must be finished under the same "conditions", however a complete wet round will be used if the rain is there for a longer period. When it starts raining during any final the race will continue. Only in case of thunder and lightning and/or heavy winds the race director can decide to stop the race due to safety reasons.

### 5.5. OPENING CEREMONY:

An opening ceremony will take place on Tuesday at 18.30. Competitors will participate in a welcoming procession. Each national team is asked to wear similar shirts. A flag and sign bearing the name of each country will be provided by the organiser for each team. At the opening ceremony a Concourse d' Elegance will be held in one category. The category will be the best "paint job". There will be one (1) trophy for the winner.

### 5.6. RACE PACKAGE:

During registration, every driver will be given an envelope which includes: A detailed schedule including starting times of each heat, 3 sets of numbers for the car, 3 sets of numbers for the wing, 1 number for the transmitter, 1 badge for the driver which allows him/her pit access and 1 badge for the mechanic, furthermore must 1 badge for the country's Team Manager also be issued. Also included in the package there must be a sketch showing the correct positioning of the car numbers on the body shell.

Two badges will be given to each competitor, blue for the driver, yellow for the mechanic. The driver's badge must show his passport-size photograph. The designated Team Manager from each country will receive an orange badge upon registration of his drivers.

### 5.7. ACCESS TO PITS AND TRACK

Orange badges/team managers:	pits, staging area, special viewing area
Blue badges/drivers:	drivers' stand, pits, staging area
Yellow badges/mechanics:	pits, staging area
Green badges/Press:	pits, staging area, special viewing area
Red badges/race officials:	all areas
Grey badges/IFMAR officials:	all areas

### 5.8. PITS:

Places are allocated for the duration of the World Championship. Places are grouped by country and marked by sign plates. Pits are covered. Every competitor will have a 60 x 120 cm (2 x 4 feet) table space.

Pits are equipped with either: 120 V/60 or 220 V/50 AC.

12 V DC (limited) in starting area

### 5.9. DISPLAY / DISTRIBUTION OF RESULTS:

The display of the positions in a specific heat or final will be done in the pits and in the Team Managers'/Press stand.

At the end of each heat (every 15 minutes) or of the finals, a copy of each competitor's lap sheet will be available for checking and information. Copies of the time-lap sheets of all cars of the heat or the final will be displayed with the result.

At the end of each round results of the general classification will be available.

### 5.10. ROSTRUM:

Drivers' rostrum, pit lane.



Mechanics must at all times pit in the position corresponding to the driver. i.e. mechanics of # (1) on the stand must use pit position 1. See drawing.

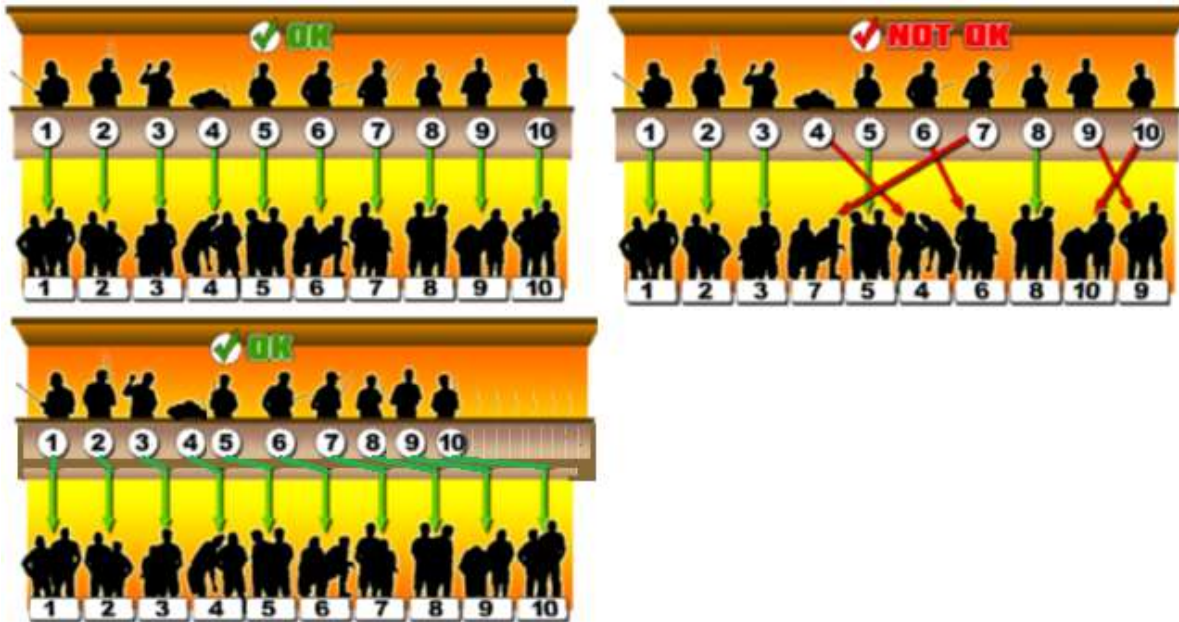

During finals, position on the drivers stand will be selected by drivers in order of qualifying position, i.e. No. 1 qualifier has first choice, No. 2 qualifier has second choice, etc.

For all heats and Finals two (2) mechanics are allowed per car. That can be the Mechanic and a team manager or 2 mechanics but a maximum of 2 people.

The only exception to this is an interpreter may be allowed only if there is sufficient space available and neither the driver nor their pit assistants speak enough English as to be able to understand the referee(s) or race control. This person may not assist in any other way, and must seek approval pre-approval from the race director.

#### 5.11. PADDOCK AREA:

Places are allocated for the duration of the World Championship. Places are grouped by country and marked by sign plates. Pits are covered. Every competitor will have a 60 x 120 cm (2 x 4 feet) table space. Pits are equipped with either: 120 V/60 or 220 V/50 AC.

Track specs

#### 5.12. MARSHALLING:

The Organizer is required to supply marshals for all finals. If the organizer cannot supply marshals for qualifying then the drivers will perform the marshalling.

If the drivers are required to marshal then they will marshal the heat following their racing heat. Drivers in the final heat of a group will marshal the first heat of that group. Substitutes are not allowed except if the driver is physically unable and authorized by the race director. Marshals who are not in position one minute prior to the start of the heat will be penalized by the loss of their best qualifying time.

The organizer must provide marshals for vacant positions for which there are no available drivers.

The organizer must supply gloves for use by the marshals at their discretion. All marshals must wear close-toe shoes.



The organizer must provide running marshals to allow the proper marshals to remain at their positions. Running marshals must return disabled cars to the pit area. Only marshals and authorized personnel are allowed on the track while racing is in progress.

### **5.13. FLAGS:**

Start – green flag or national flag

Finish – chequered flag for final only

Blue – The car which is blue flagged must allow the car behind him to pass.

Yellow – Danger on the track - slow down

Black & white – Official warning to the car which is flagged (diagonal)

Black – The car in question must stop immediately in the pits

Green – Track open

Red – Track closed. All cars must stop immediately.

The black and white diagonal and the blue flags are recommended but are not compulsory.

All flags are under the direction of the Race Director who can delegate and authorize their use.

### **6. RACE-OFFICIALS / REFEREES:**

See IFMAR general Rules

#### **6.3 PROTEST AGAINST A COMPETITOR OR ORGANIZER:**

Protest must be entered by the Team Manager, in writing, in English language, within 10 minutes after the display of the result or after the incident it concerns, with a deposit of \$50 U.S. or equivalent. The time of display of the result will be written on the result sheet. The deposit is forfeited if the protest is not upheld and the deposit is returned if protest is justified. Protests may be handed to the Race Director or an IFMAR Official. Protests are processed by the Race Director and, if necessary, by the Jury. Appeal to IFMAR may be made. IFMAR is not obliged to handle such appeal. Deposit returned if protest is upheld.

#### **6.4 PENALTIES and SANCTIONS:**

During finals, participants will be allowed to change the bodies of the car without the authorization of the Race Director, providing the bodies are of the same type. In the event of a different body being fitted to the car, the Race Director must give his permission before the participant re-enters the race.

Any illegal modification or change made to the car which is found during the technical inspection at the end of the race will automatically entail disqualification of the participant.

EXCEPTIONS: Tolerances allowed in technical inspection for fuel tanks

Any damage incurred during a heat or final will not entail a forced stop or disqualification of the participant except in the following cases:

- loss of a body (the spoiler does not count as part of the body)
- loss of the silencer or its ability to silence the engine
- a car which becomes dangerous or un-drive able.

The car in question may re-start after the repairs have been affected.

Any car which, by the fault of another driver, is damaged or obstructed during a heat or final cannot, under any circumstances, be allowed to re-run in another heat.

All participants must strictly observe the instructions given by the Race Director, Jury and Referees. The bad sportsmanship and behavior of any competitor, even outside the official

race meeting, which could injure the image and promotion of the sport, may become the object of an official, national or international sanction.

**6.5 IN GENERAL:**

Refer to the general rules in 1/8<sup>th</sup> with reference to Track Specifications, (IFMAR)-officials, penalties, lap counting requirements, **rain situation**, monitors in pit and pit lane etc.

**IFMAR ASSOCIATED PLATINUM MEMBERS.**

IFMAR would like to thank its Platinum members for their membership.

IFMAR GT rules 2024 DRAFT